

HV510

0.75kW~560kW

nnn._fg\n`e[.Zfd

603063

HV510
HD2000
0.75kW~22400kW

HV610
HD8000
4MVA~102MVA

HV350
HV500



6

30

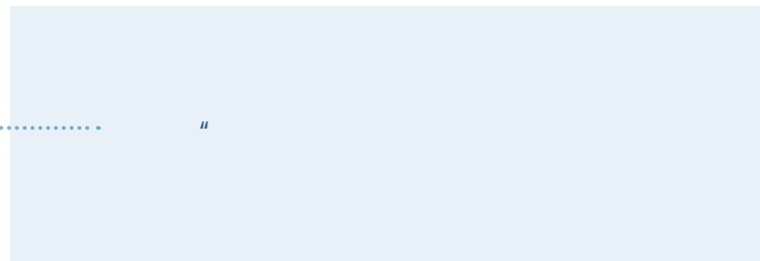

HV510

01 HV350



02 HV510



03 HV610



04 HV500



05 HD2000

06 HD8000



CNAS

HV510系列高性能变频器

HV510

5

HV510

HV510

HV510 - A0 4 T 00075

变频器系列名：
HV510 hopeVert

电路拓扑及冷却方式：
A0

电压等级：
4 380V

相数：
T

功率等级：

00075	7.5kW	11kW
00150	15kW	18.5kW

制动单元信息：
B



	11	PLC PID	UP/DOWN	AI1/AI2/AI3	DI5
	66	DI			
	48	DO	23	AO HDO	
		AI1 AI2	0V-10V/ 0 (4) mA-20mA		
	DI1-DI5	5		100kHz	/
	DI5				
	2			0V-24V	50mA
	DO1			100kHz	
	1	0V-10V/ 0 4 mA-20mA			
	1	FormC	+		
	1	A B	RS485		
I/O	DI6-DI8	3			/
	DO3	1			
	AI3	1		-10V~+10V	
	AO2 AO3	2		0-10V/0-20mA	
	1		+		
	1		PT100	PT1000	KTY84



LED	
LED	
LCD	
	MF.K



	1000	1000 ~3000	100	1%
	-25 ~+40	40	55	
	15%-95%			
	3M3 IEC60721-3-3			
	-40°C~+70°C			
	IP20			

HV510

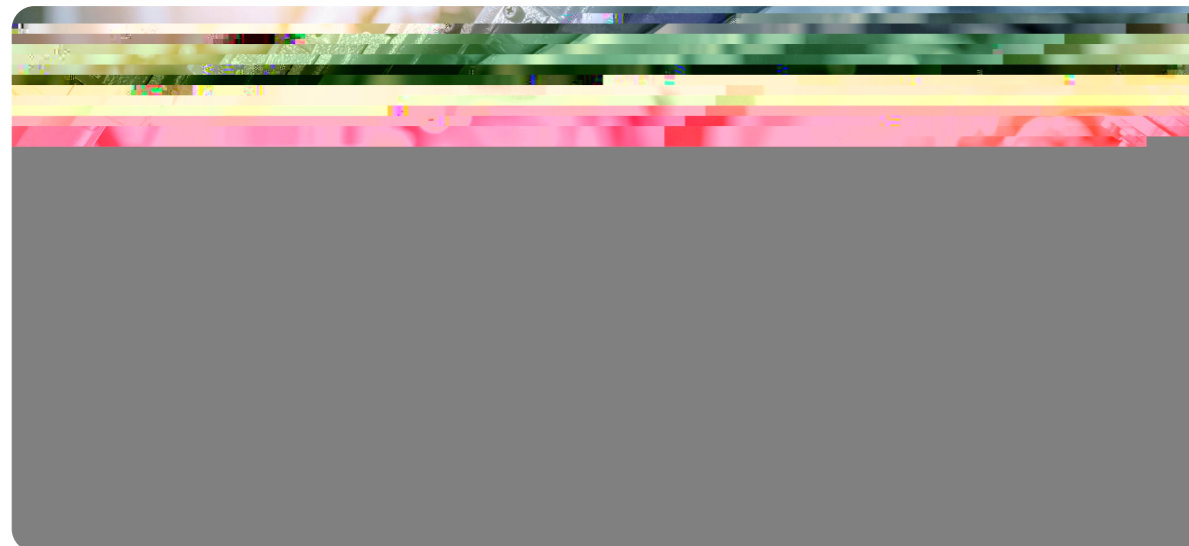

HV510



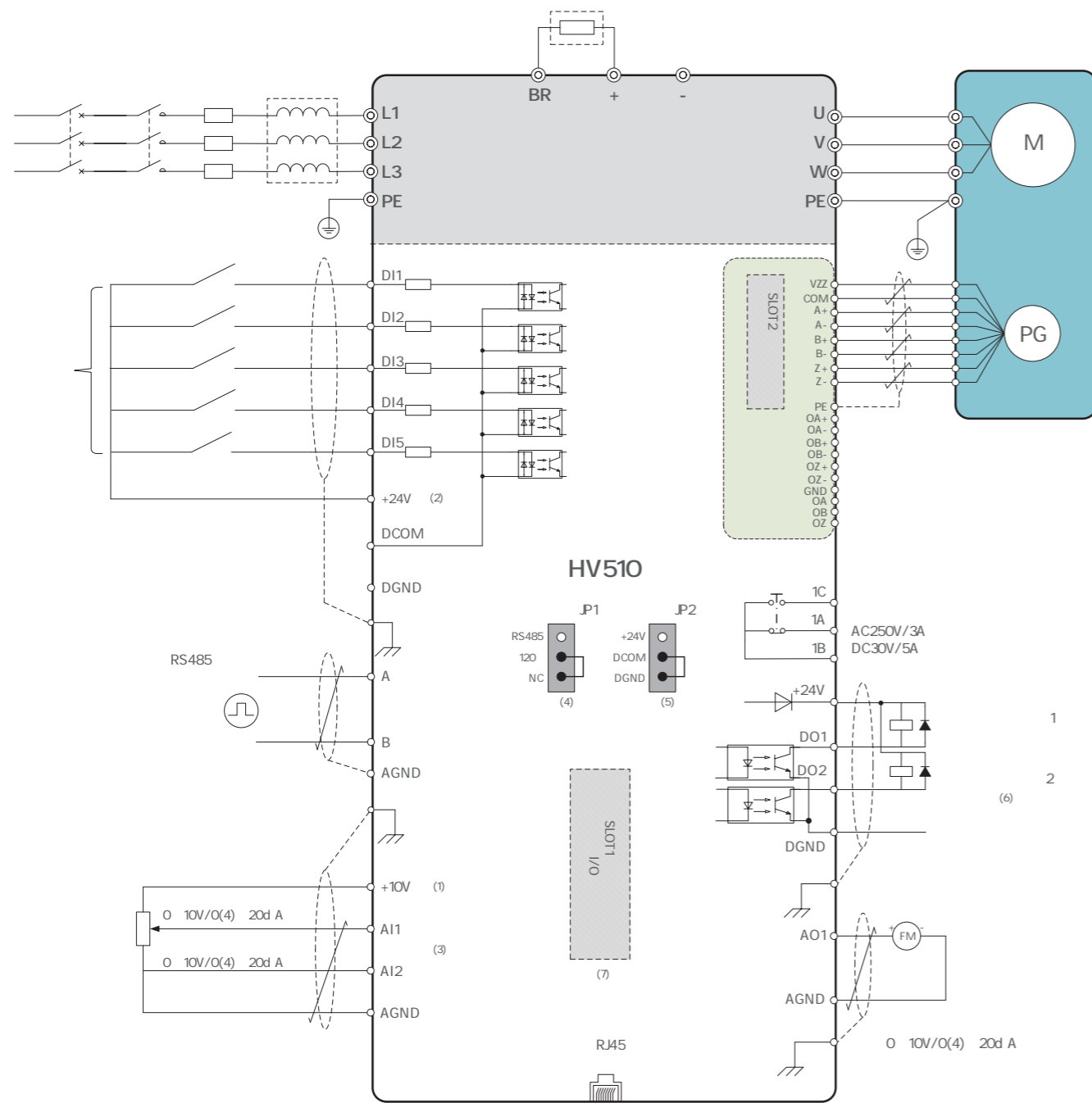

1	+10V	25mA
2	+24V	50mA
3	A11 A12	500
4	RS485	120
5	DI1-DI5	NPN PNP
6		50mA
7	I/O	

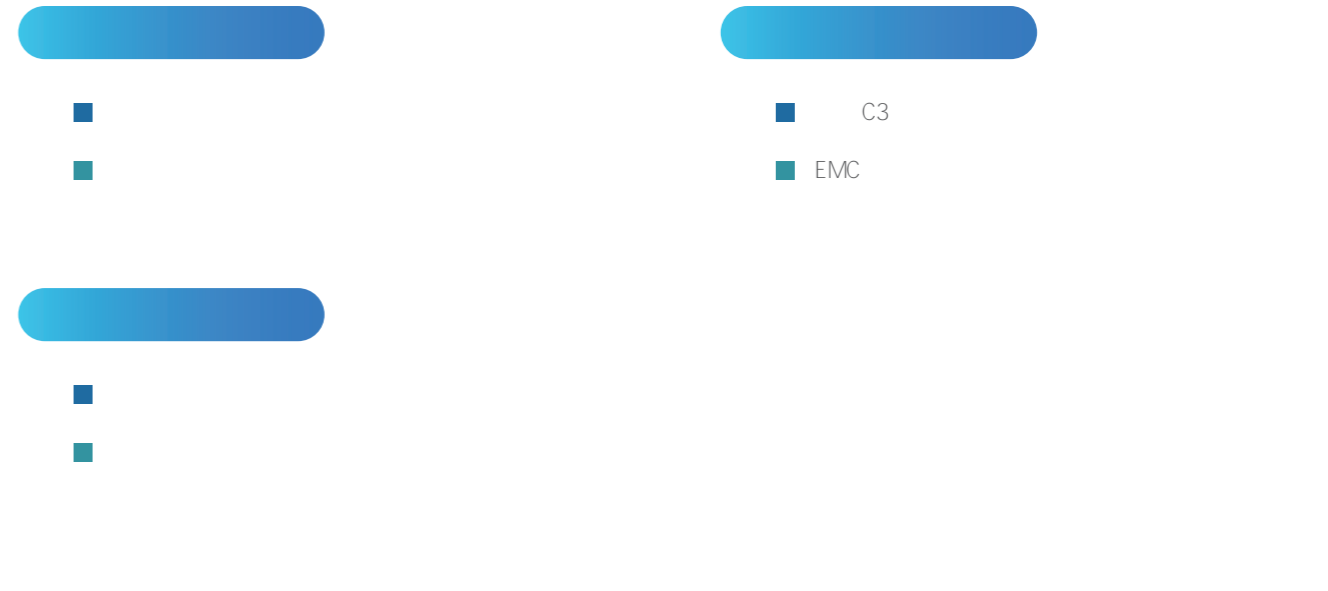

- C3
- EMC



HV510

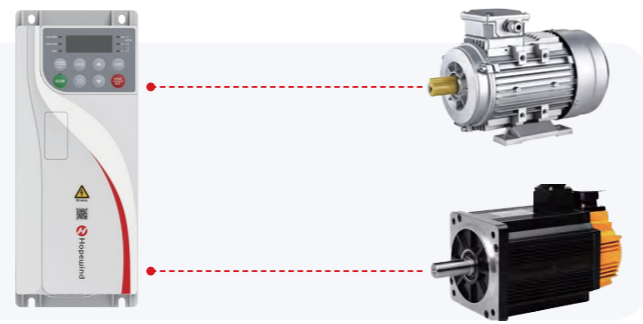

-
-
-

-
-

-
-
-

- 110% 60s 150%
- 150% 60s 200%

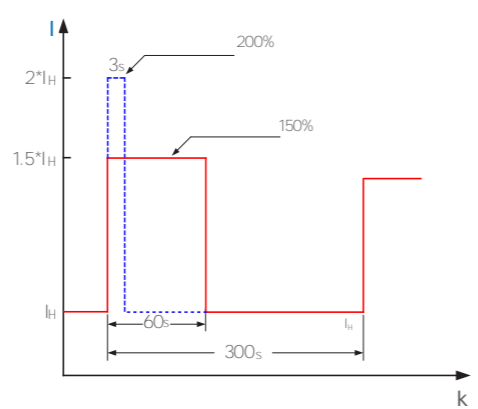
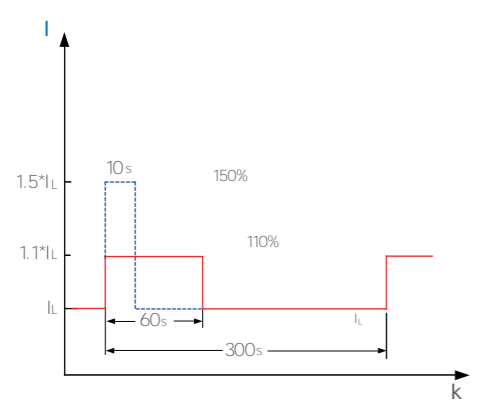

- 1500Hz

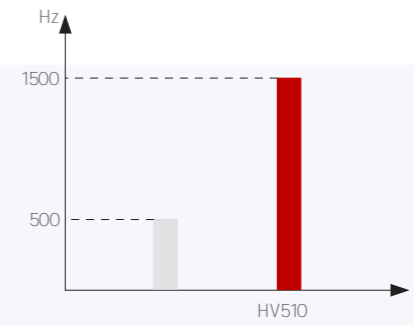

- Profbus-DP Profnet
- IO CANopen Modbus TCP/IP Ethercat EtherNet/IP

- I/O
- 110kW

132kW

I/O

LED

LCD

I/O

DP

PG

PN

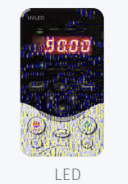

LED

LCD



HV510



- 2
- PLC 16
- PID
- I/O
-
-
-
-
- PWM
-



HV510系列高性能变频器

	mm ^W	mm ^H	mm ^D	M1 mm	M2 mm	H2 mm	mm	kg
FA	76	232	175.5	55	55	221	5	1.7
FB	95	232	175.5	70	70	221	5	1.8
FC	121.5	272	187	90	90	262	6	3.3
FD	140	377	237	105	105	357	6.5	5.5
FE	240	500	225	160	160	485	7	16
FF	270	615	240	200	200	594	9	24
FG	335	712	255	230	230	688	9	38
F8	300	880	450	160	160	825	9	105
F9	300	980	545	160	160	925	9	122
F10	300	1100	545	160	160	1050	9	156
F11	330	1220	590	110	220	1150	9	209

HV510

	mH	A	mH	A
HV510-A04T00007B	7	2.2	1.7	4.4
HV510-A04T00015B	3.5	4.4	1.3	6
HV510-A04T00022B	2.4	6.4	0.8	10
HV510-A04T00040B	1.4	12	0.6	14
HV510-A04T00055B	1	16	0.43	18
HV510-A04T00075B	0.8	20	0.3	26
HV510-A04T00110B	0.52	30	0.23	34
HV510-A04T00150B	0.4	40	0.2	40
HV510-A04T00185B	0.31	50	0.16	48
HV510-A04T00220B	0.26	60	0.12	63
HV510-A04T00300(B)	0.2	81	0.1	78
HV510-A04T00370(B)	0.16	100	0.08	95
HV510-A04T00450(B)	0.13	121	0.06	130
HV510-A04T00550(B)	0.1	148	0.05	155
HV510-A04T00750(B)	0.08	202	0.04	190
HV510-A04T00900(B)	0.07	225	0.035	220
HV510-A04T01100(B)	0.06	275	0.03	265
HV510-A04T01320(B)	0.041	345	0.021	325
HV510-A04T01600(B)	0.036	385	0.017	400
HV510-A04T02000(B)	0.033	420	0.016	435
HV510-A04T02200(B)	0.029	480	0.014	495
HV510-A04T02500(B)	0.026	540	0.013	535
HV510-A04T02800(B)	0.023	605	0.011	640
HV510-A04T03150(B)	0.021	680	0.01	705
HV510-A04T03550(B)	0.018	770	0.009	785
HV510-A04T04000(B)	0.016	865	0.008	860
HV510-A04T04500(B)	0.032	840	0.0077	905
HV510-A04T05000(B)	0.026	960	0.0067	1040
HV510-A04T05600(B)	0.022	1100	0.006	1155

	()	(A)	R() P
HV510-A04T00007B	120	7	750 /150W
HV510-A04T00015B	80	10.5	350 /320W
HV510-A04T00022B	80	10.5	250 /450W
HV510-A04T00040B	47	17.5	150 /750W
HV510-A04T00055B	29.6	28	150 /750W
HV510-A04T00075B	29.6	28	100 /1125W
HV510-A04T00110B	29.6	28	100 /1125W
HV510-A04T00150B	29.6	28	30 /3750W
HV510-A04T00185B	29.6	28	30 /3750W
HV510-A04T00220B	24	35	30 /3750W
HV510-A04T00300(B)	24	35	25 /4500W
HV510-A04T00370(B)	16	52.5	25 /4500W
HV510-A04T00450(B)	16	52.5	25 /4500W
HV510-A04T00550(B)	8	105	10 /14000W
HV510-A04T00750(B)	8	105	10 /14000W
HV510-A04T00900(B)	5.6	157	6 /21000W
HV510-A04T01100(B)	5.6	157	6 /21000W
HV510-A04T01320(B)	3	250	5 /27000W
HV510-A04T01600(B)	2.6	288	4 /33000W
HV510-A04T02000(B)	2.4	313	3.3 /41000W
HV510-A04T02200(B)	2.4	313	3 /45000W
HV510-A04T02500(B)	2.4	313	2.8 /48500W
HV510-A04T02800(B)	1.8	417	2.4 /56500W
HV510-A04T03150(B)	1.8	417	2.1 /65000W
HV510-A04T03550(B)	1.4	536	1.9 /71000W
HV510-A04T04000(B)	1.4	536	1.7 /80000W
HV510-A04T04500(B)	1.2	625	1.6 /85000W
HV510-A04T05000(B)	1.2	625	1.6 /85000W
HV510-A04T05600(B)	1	750	1.2 /115000W

HVLED	LED	
HIC300-OP-30	LCD	
HVKMB		
HVCOM-USB		hopelnsight
HVIO-01	I/O	3 1 1 1 -10V 10V 2 0 10V/0 20mA 1 PT100 PT1000 KTY84 1
HVIO-02	I/O 2	1 0-20mA 2 0-20mA 1 PT100 PT1000 PTC 1
HVIO-03	I/O 3	2 3 1 1 1 -10V-10V 2 0-10V/0-20mA 1 PT100 PT1000 KTY84 1
HVPG-ABZ-01		ABZ
HVPG-ROT		
HVCOM-DP-H	Prof bus-DP	Prof bus-DP
HVCOM-PN-H	Profnet	ProfnetIO
HVCOM-TP-H	Modbus TCP/IP	Modbus TCP/IP
HVCOM-EC-H	EtherCAT	EtherCAT
HVCOM-EN-H	EtherNet/IP	EtherNet/IP
HVCOM-DP-V	Prof bus-DP	Prof bus-DP FA FB FC HVCOM-DP-V
HVCOM-PN-V	Profnet	ProfnetIO FA FB FC HVCOM-PN-V
HVCOM-TP-V	Profnet	Modbus TCP/IP FA FB FC HVCOM-TP-V
HVCOM-EC-V	Profnet	EtherCAT FA FB FC HVCOM-EC-V
HVCOM-EN-V	Profnet	EtherNet/IP FA FB FC HVCOM-EN-V
HVCOM-CA	CANopen	CANopen

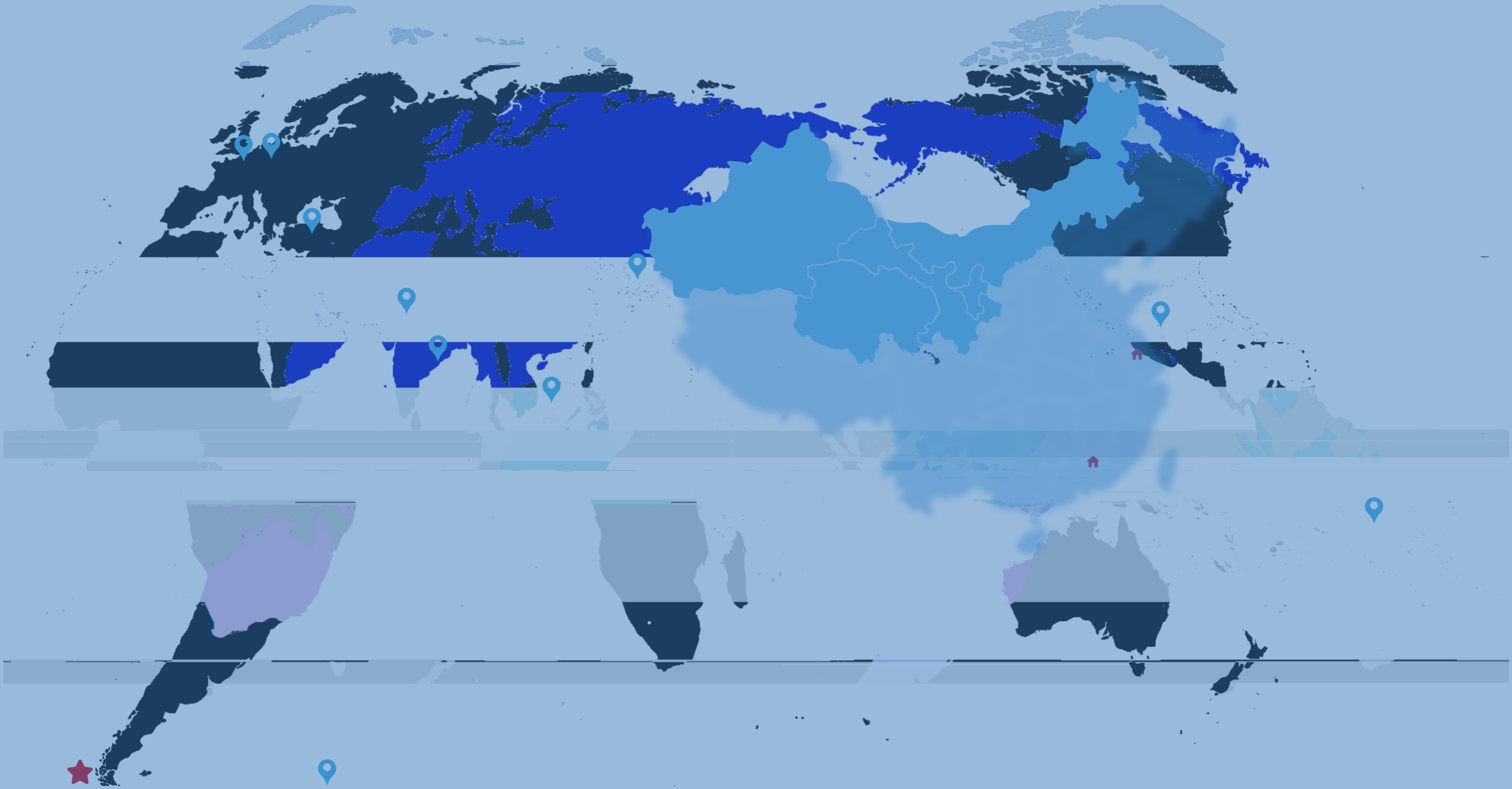



400-8828-705

+86-755-86026786

nnn_f g\ n `e[.Zf d